

BA310POL | ADVANCED POLARIZATION MICROSCOPE



Based on the success of its popular BA Microscope Series for Bio-Medical applications, Motic is pleased to introduce the new BA310POL, an extremely powerful yet affordable Polarization microscope for Transmitted light samples. The BA310POL is designed for the examination of birefringent samples from petrography and mineralogy, and can also be used for the synthetic materials industry where repeatable observations can be performed with efficiency and reliability. The BA310POL also works especially well in Educational applications of material professions, where affordability and ease-of-use are key requirements.

The New BA310POL

A reliable Polarization microscope has to fulfill unique demands in optical performance dictated by a diverse selection of samples. Based on the ease-of-use concept developed through Motic's successful BA Series, the BA310POL follows these same principles by paying careful attention on **strain-free optical components** as well as smooth mechanical movements.

The built-in **6V/30W Full Koehler** Halogen illumination offers a powerful and adjustable light source. **Field diaphragm** and **aperture diaphragm** help to optimize image quality by reducing stray light and increasing contrast. Further, the field diaphragm plays an essential part in the **Conoscopic observation method**.

Following Motic's newest developments of lead-free manufacturing in full compliance with RoHS regulations, the strain-free versions of the **new EC Plan Achromatic** lenses naturally provide optimal image contrast through a multi-layer lens coating. Together with a **fully corrected tube lens**, Motic creates a **superior optical intermediate image** without any color fringes. The **Bertrand lens**, as an integral part of a Polarization microscope, is both focusable and centerable, thus giving access to the back focal plane of each objective. The Trinocular BA310POL also includes a standardized **ISO photo port**.

The **pre-centered rotating stage** with 160mm diameter has got a **hard coated and chemical resistant surface**; where a **high precision ball-bearing mechanism** ensures **smooth rotation**, while the **360° scale** gives orientation and allows semi-quantitative measurements.

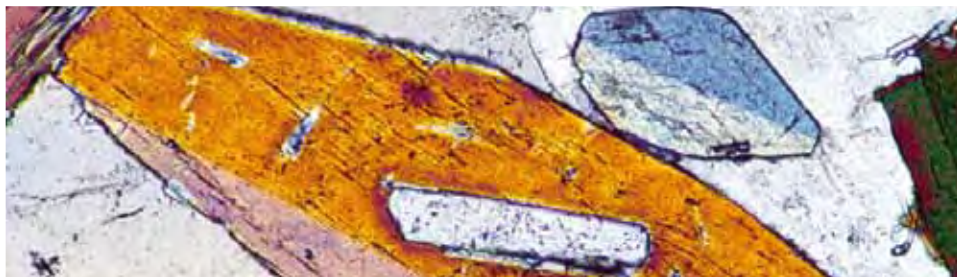



Objectives

For improved optical performance of the BA310POL microscope, Motic introduces its new **strain-free EC Plan Achromatic objectives**. These objectives are made of high quality glass and follow the successful Motic CCIS® Optical concept. Multi-layer coating ensures improved contrast and image quality. The tube lens provides a completely corrected intermediate image with photo port documentation based on maximum image quality.

The ball bearing **4-fold nosepiece** shows a **reversed orientation** of the lenses. In reference on a given objective position, all other objectives can be centered individually by countersunk screws. All centering tools are included as part of the BA310POL microscope package.

| Magnification | N.A. | W.D.(mm) |
|---------------|------|----------|
| EC Plan 4X | 0.10 | 15.90 |
| EC Plan 10X | 0.25 | 17.40 |
| EC Plan 20X | 0.45 | 0.90 |
| EC Plan 40X | 0.65 | 0.50 |
| EC Plan 60X | 0.80 | 0.35 |

Illumination

The **Transmitted light illumination** is based on a **6V/30W** Halogen light source. With an **adjustable field diaphragm** and **aperture diaphragm**, repeatable even and **homogenous illumination** is guaranteed. Precise use of both diaphragms creates a maximum image quality in terms of contrast. The **strain-free Achromatic Swing-out condenser** with N.A. 0.90/0.13 also further enhances the best possible illumination quality.



Eyepiece Tubes

Incorporating an **interpupillary distance of 55-75mm**, the BA310POL observation tubes guarantee hours of fatigue-free viewing due to an **ergonomic viewing angle of 30°**. A large **Field of View (20mm)** enables fast and comfortable screening. The **Trinocular tube** allows digital documentation by using a wide variety of digital cameras, with a **standard 20/80 light split** through the photo/video port. As an **option**, a **0/100 light split** tube is available.

Motic recommends the use of CCD cameras in polarization work as this technology gives advantages in color fidelity and reproduction. To fulfill the requirements of objective centration, the eyepiece tube for the right eye is equipped with 2 notches, allowing the orientation of the built-in eyepiece crosshair in orthogonal and diagonal cross positions.

Eyepieces

The **standard eyepieces, N-WF 10X/20** with high eyepoint for eyeglass wearers, made of high quality optical glass, provide consistent diopter adjustments for both eyes.

As required for polarization work, one eyepiece is equipped with a **fixed crosshair reticule**.

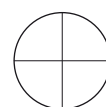

Orthogonal cross hair

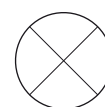

Diagonal cross hair



Stage

The BA310POL microscope stand carries a **pre-centered stage** of 160mm diameter. The hard coated and chemical resistant surface is designed to withstand abrasion under rough usage. A high precision ball-bearing mechanism ensures smooth movement and accurate rotation, while a **continuous 360° scale** with **1° increments** allows precise positioning of the sample. The standard package comes with sample clamps to fix the slides.

A sub-stage condenser carrier is supplied with a **fully rotatable polarizer**, with a 90° click-stop implemented.





Intermediate Tube

As an integral part of the BA310POL setup, the **Intermediate tube** carries an **Analyzer**, **Bertrand lens** and **compensator slot**. The **Analyzer** is **360° rotatable**, with a complete scale of 1° increment. A fixing screw helps to freeze the position of best extinction.

The built-in **Bertrand lens** is **focusable and centerable**, giving access to the back focal plane of the objectives, especially when working in the Conoscopic method. A **DIN compliant compensator slot** (20mm x 6mm) allows the use of all established compensators.

Compensators

To suit the specifics of **semi-quantitative examinations**, a set of compensators are available.

The First-Order Red (Tint plate; $\lambda = 550\text{nm}$) certainly will be of most interest, while the use of Quarter-wave plate $\lambda/4$ and Quartz wedge $1-4\lambda$ are less common.

Today, accurate documentation has been established as an important part in natural sciences and industrial quality control. Like in all Motic's BA series, the new BA310POL offers the choice between several imaging options.



Documentation

Standard Photomicrography

The traditional use of a **single lens reflex camera** (analogue or digital) requires the Trinocular version of the BA310POL. The adaptation of the camera consists of a **mechanical adapter combined with a photo eyepiece** (2.5X or 4X).

The **necessary T2 adapter** referring to the camera model is supplied by the camera manufacturer. This setup delivers high resolution images of small fields.

Digital Documentation

A more convenient setup is provided through Motic's philosophy of **easy image digitization**. The combination of the BA310POL with a member of the Moticam series of digital cameras delivers excellent live images, which can easily be stored for future usage.

All Motic cameras come equipped **with software** to transform the BA310POL into an **analysis and documentation station**.

As **colour fidelity** is a **basic requirement** for polarization work, Motic recommends the use of **CCD sensor technology**, implemented in our Research grade Moticam Pro Line. This technology is superior to the CMOS technique especially when true colours are of special interest.

For further details on our range of cameras, as well as the different CCD adapters, please contact your nearest Motic office or your local authorized Motic reseller.

Anti-Fungus Design

To protect the system from fungus growth in high-humidity environments, an advanced anti-fungus treatment has been applied to prolong the life of both microscope mechanics and optics.

CCD Adapter

To enhance image reproduction quality by digital documentation, a **set of CCD adapters**, following the ISO standard with 38mm diameter, are available.

The appropriate adapter has to be chosen in relation to the sensor chip size of the used digital camera. The following "magnifications" are available: **1X, 0.65X, 0.5X**.



BA310 POL Standard Specifications

| | |
|--------------------------|---|
| Model | BA310 Polarizing Microscope |
| Optical System | Color Corrected Infinity Optical System [CCIS®] |
| Observation Tube | Widefield binocular 30° Widefield Trinocular 30° - light distribution 100:0/20:80 |
| Eyepieces | Widefield High eyepoint, N-WF10X/20mm, diopter adjustment on both eyepieces, rubber eyecup (paired), cross hair on one eyepiece |
| Intermediate tube | 360° rotatable analyzer; built-in focusable & centerable Bertrand lens |
| Nosepiece | Reversed quadruple revolving nosepiece, 3 centerable positions |
| Stage | 360° rotatable stage |
| Condenser | Achromat swing-out condenser N.A. 0.90/0.13 (strain-free) with iris diaphragm |
| Polarizer | Rotatable polarizer, fixed on condenser carrier |
| Focusing | Brass gears Z-Axis movement 20mm Fine focus with 2µm minimum increment, Coarse focus with torque adjustment |
| Illumination | Koehler illumination Quartz Halogen 6V/30W with intensity control |

BA310 POL Schematic Diagrams (units: mm)

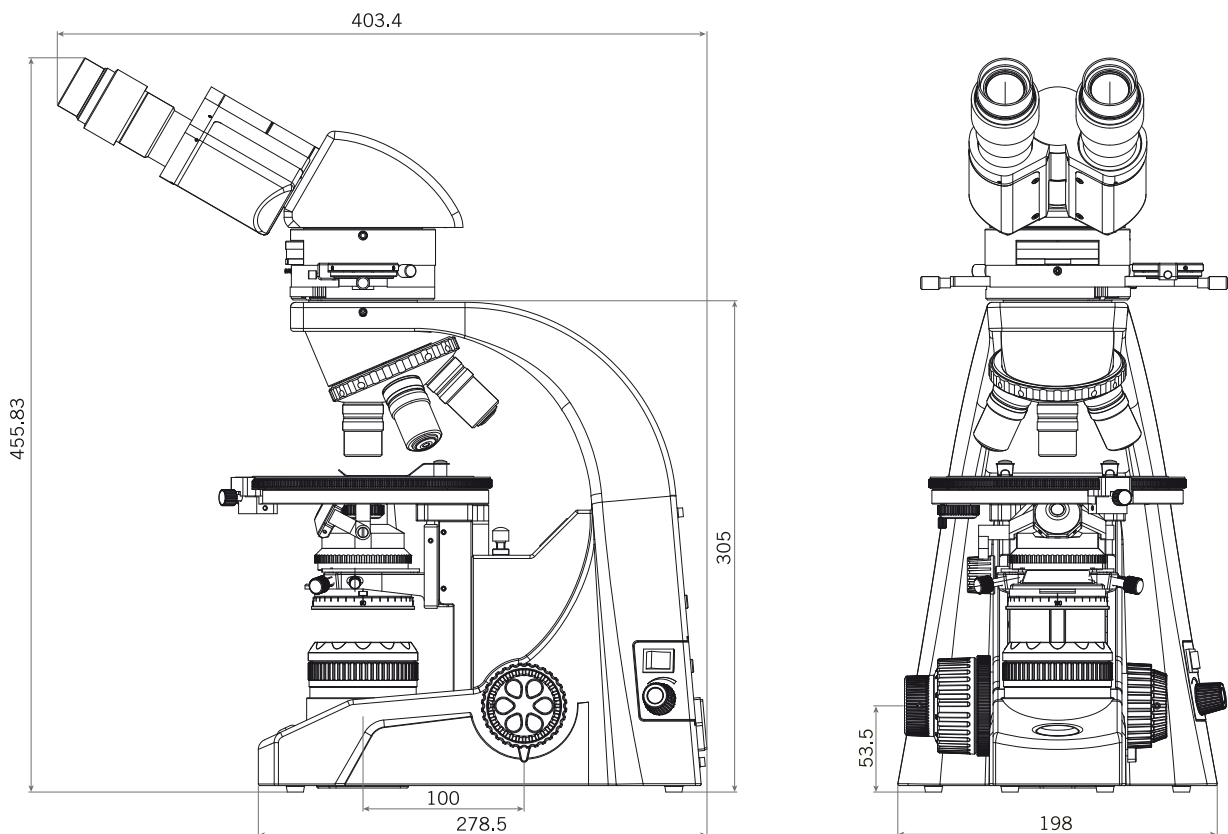

BA310 POL / Schematic Diagram

